

Testing Items		Testing Method	Typical Value	Unit
Viscosity		ASTM D445	350	mPa·s (25°C)
Density		ASTM D792	1.15	g/cm ³
Color		-	Lake-Blue	-
Temperature Properties		ASTM D648	60	°C (0.45 MPa)
Shore Hardness		ASTM D2240	80	Shore D
Tensile Properties	Ultimate Tensile Strength	ASTM D638	45	MPa
	Tensile Modulus	ASTM D638	2850	MPa
	Elongation	ASTM D638	7.2	%
Flexural Properties	Flexural Strength	ASTM D790	85	MPa
	Flexural Modulus	ASTM D790	2560	MPa
Impact Properties	Notched IZOD	ASTM D256	34	J/m

Notes:

1. It was tested with 3D printed specimen.
2. All test pieces were printed with a Rayshape Shape 1 3D printer.

Specimens

Fig 1. Tensile testing specimen

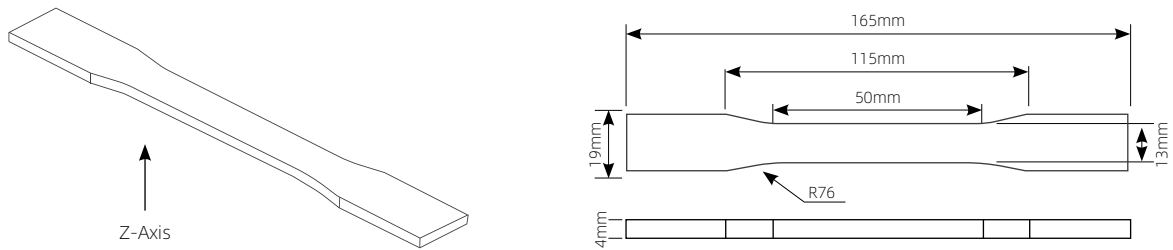

Fig 2. Impact testing specimen

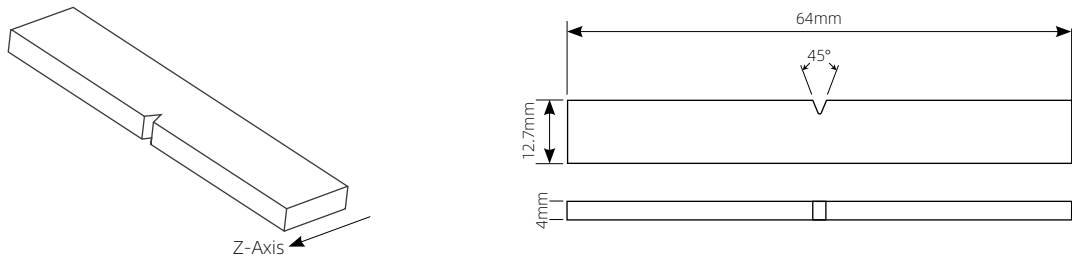
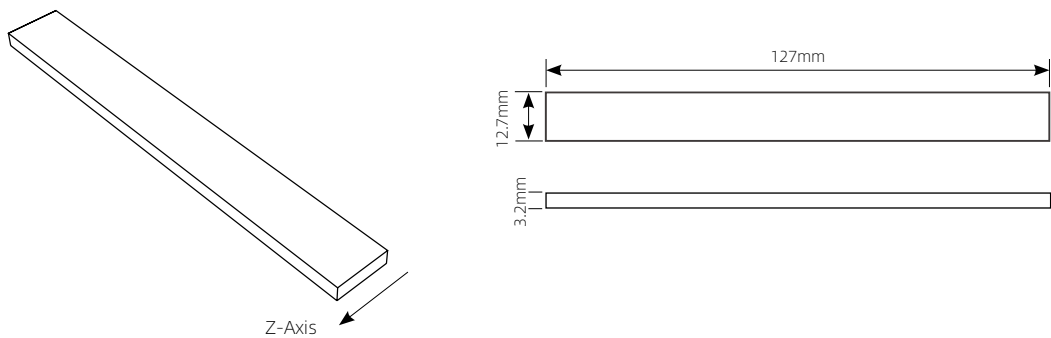

Fig 3. Flexural testing specimen



Disclaimer

The typical values presented in this data sheet are intended for reference and comparison purposes only. They should not be used for design specifications or quality control purposes. Actual values may vary significantly with printing conditions. Enduse performance of printed parts depends not only on materials, but also on part design, environmental conditions, printing conditions, test conditions, etc. Product specifications are subject to change without notice.

Each user is responsible for determining the safety, lawfulness, technical suitability, and disposal/recycling practices of RayShape materials for the intended application. RayShape makes no warranty of any kind, unless announced separately, to the fitness for any particular use or application. RayShape shall not be made liable for any damage, injury or loss induced from the use of Mankati materials in any particular application, as well as for identifying the proper disposal (or recycling) method consistent with applicable environmental laws and regulations.

RAYSHAPE[®]